

The Polar $[\text{WO}_2\text{F}_4]^{2-}$ Anion in the Solid State

Kevin R. Heier, Alexander J. Norquist, P. Shiv Halasyamani,[†] Angel Duarte, Charlotte L. Stern, and Kenneth R. Poeppelmeier*

Department of Chemistry, Northwestern University, Evanston, Illinois 60208-3113

Received July 22, 1998

The *cis*- $[\text{WO}_2\text{F}_4]^{2-}$ anion is inherently acentric and contains polarizable W=O bonds, making it a good candidate for second-harmonic generation (SHG). However, the orientational disorder commonly found in crystal structures containing $[\text{WO}_2\text{F}_4]^{2-}$ must be understood as a first step toward engineering a polar SHG material with this anion. The strategy of crystallizing the $[\text{WO}_2\text{F}_4]^{2-}$ anion with two different cations, which was successful in ordering the related $[\text{NbOF}_5]^{2-}$ and *cis*- $[\text{MoO}_2\text{F}_4]^{2-}$ anions, is able to order one of the two W=O bonds. Close inspection of bond lengths and anisotropic thermal ellipsoids in disordered $[\text{WO}_2\text{F}_4]^{2-}$ compounds gives insight into disorder mechanisms and suggests strategies for eliminating orientational disorder. Crystal data: for $[\text{pyH}]_2\text{-}[\text{Cu}(\text{py})_4(\text{WO}_2\text{F}_4)_2]$, tetragonal, space group *I4*₁22 (No. 98), with *a* = 11.339(2) Å, *c* = 30.489(6) Å, and *Z* = 4; for $\text{Cu}(\text{pyz})_2\text{WO}_2\text{F}_4\cdot(\text{pyz})(\text{H}_2\text{O})$ polymorph I, tetragonal, space group *I4/mcm* (No. 140), with *a* = 9.745(1) Å, *c* = 16.565(3) Å, and *Z* = 4; for $\text{Cu}(\text{pyz})_2\text{WO}_2\text{F}_4\cdot(\text{pyz})(\text{H}_2\text{O})$ polymorph II, tetragonal, space group *P4/mmm* (No. 123), with *a* = 6.886(3) Å, *c* = 8.300(2) Å, and *Z* = 1.

Introduction

Early transition metal oxide fluoride anions such as $[\text{NbOF}_5]^{2-}$, *cis*- $[\text{MoO}_2\text{F}_4]^{2-}$, and *cis*- $[\text{WO}_2\text{F}_4]^{2-}$ are inherently acentric and have polarizable metal–oxygen bonds. As such they are potential candidates for use in new second-harmonic-generating (SHG) materials. However, these acentric anions are nearly always found to crystallize in centrosymmetric space groups, eliminating possible SHG effects.¹ Fundamental understanding of the crystallization of oxide fluoride anions is needed to increase the probability of engineering a crystal material in which they will adopt the desired polar orientation.

The first step in demonstrating such a fundamental understanding is to circumvent the problem of orientational disorder commonly found in crystal structures containing metal oxide fluoride anions. Recently the strategy of crystallizing the anions with two different cations, tetrakis(pyridine)copper(II) ($[\text{Cu}(\text{py})_4]^{2+}$) and pyridinium (pyH^+), was successful in ordering the $[\text{NbOF}_5]^{2-}$ and $[\text{MoO}_2\text{F}_4]^{2-}$ anions.² The accurate determination of bond lengths afforded by the crystallographic order allows estimation of the charge distributions on the anions through the use of bond valence calculations.³ This is important because the charge distribution on the anions appears to be the most important factor determining how they crystallize.²

In this work, the difficult task of ordering the $[\text{WO}_2\text{F}_4]^{2-}$ anion is undertaken. Of the known crystal structures containing $[\text{WO}_2\text{F}_4]^{2-}$ (Table 1),^{4–9} only $\text{Na}_2\text{WO}_2\text{F}_4$ displays the anion in a completely ordered orientation (Figure 1, Table 2).⁵ The technique of crystallizing $[\text{WO}_2\text{F}_4]^{2-}$ with two different cations is successful in ordering one of the W=O bonds, while the other

Table 1. Crystal Structures Containing the *cis*- $[\text{WO}_2\text{F}_4]^{2-}$ Anion

compound	ref
$\text{CuWO}_2\text{F}_4\cdot 4\text{H}_2\text{O}$	4
$\text{Na}_2\text{WO}_2\text{F}_4^a$	5
$[\text{C}(\text{NH}_2)_3]_2\text{WO}_2\text{F}_4$	6
$\text{Cs}_2\text{WO}_2\text{F}_4$	7
$\text{K}_2\text{WO}_2\text{F}_4$	8
$\text{K}_2\text{WO}_2\text{F}_4\cdot\text{H}_2\text{O}$	8
$\text{Cu}(\text{py})_4\text{WO}_2\text{F}_4$	9
$\text{Cu}(\text{py})_2(\text{H}_2\text{O})_2\text{WO}_2\text{F}_4$	9
$[\text{pyH}]_2[\text{Cu}(\text{py})_4(\text{WO}_2\text{F}_4)_2]$	this work
$\text{Cu}(\text{pyz})_2\text{WO}_2\text{F}_4\cdot(\text{pyz})(\text{H}_2\text{O})$ I	this work
$\text{Cu}(\text{pyz})_2\text{WO}_2\text{F}_4\cdot(\text{pyz})(\text{H}_2\text{O})$ II	this work

^a Crystallographically ordered anion.

remains disordered. On the basis of close inspection of bond lengths and anisotropic thermal ellipsoids in structures containing $[\text{WO}_2\text{F}_4]^{2-}$, disorder mechanisms and strategies for eliminating orientational disorder have been suggested.

Experimental Section

CAUTION. (HF)_x·pyridine is toxic and corrosive!

Materials. CuO (99%, Aldrich), WO₃ (99%, Aldrich), pyridine (py) (99.8%, anhydrous, Aldrich), pyrazine (pyz) (99+%, Aldrich), and (HF)_x·pyridine (pyridinium poly(hydrogen fluoride), 70 wt %, Aldrich) were used as received. Reagent amounts of deionized H₂O were used in the syntheses.

Synthesis. Single crystals of each of the reported compounds were synthesized by placing appropriate amounts of reactants (see below)

- (4) Fischer, J.; de Cian, A.; Weiss, R. *Bull. Soc. Chim. Fr.* **1966**, 2646.
- (5) Chaminade, J. P.; Moutou, J. M.; Villeneuve, G.; Couzi, M.; Pouchard, M.; Hagenmuller, P. *J. Solid State Chem.* **1986**, *65*, 27.
- (6) Calov, U.; Schneider, M.; Leibnitz, P. *Z. Anorg. Allg. Chem.* **1991**, *604*, 77.
- (7) Srivastava, A. M.; Ackerman, J. F. *J. Solid State Chem.* **1992**, *98*, 144.
- (8) Jie, Z. H.; Garcia, A.; Guillen, F.; Chaminade, J. P.; Fouassier, C. *Eur. J. Solid State Inorg. Chem.* **1993**, *30*, 773.
- (9) Halasyamani, P. S.; Heier, K. R.; Stern, C. L.; Poeppelmeier, K. R. *Acta Crystallogr., Sect. C* **1997**, *53*, 1240.

* Corresponding author.

[†] Present address: Inorganic Chemistry Laboratory, South Parks Road, Oxford University, Oxford, OX1 3QR, U.K.

- (1) Nye, J. F. *Physical Properties of Crystals*; Oxford University Press: New York, 1985.
- (2) Heier, K. R.; Norquist, A. J.; Wilson, C. G.; Stern, C. L.; Poeppelmeier, K. R. *Inorg. Chem.* **1998**, *37*, 76.
- (3) Brown, I. D.; Altermatt, D. *Acta Crystallogr., Sect. B* **1985**, *41*, 244.

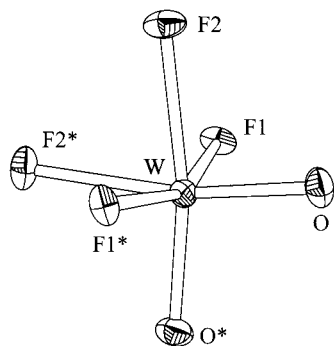

Figure 1. *cis*- $[\text{WO}_2\text{F}_4]^{2-}$ anion in $\text{Na}_2\text{WO}_2\text{F}_4$.⁵ The majority of the negative charge on the anion is distributed among the oxygen and F(2) ligands (Table 2).

Table 2. Bond Valence Sums^{a,b} for the $[\text{WO}_2\text{F}_4]^{2-}$ Anion in $\text{Na}_2\text{WO}_2\text{F}_4$ ^c

	R_i (Å)	S_i	$V - S_i$
W=O × 2	1.750(9)	1.57	0.43
W-F(1) × 2	1.932(8)	0.77	0.23
W-F(2) × 2	2.039(9)	0.58	0.42

^a Bond valence calculated with the program Bond Valence Calculator, version 2.00, C. Hormillosa, S. Healy, and T. Stephen, McMaster University (1993). ^b Valence sums calculated with the formula $S_i = \exp[(R_0 - R_i)/B]$, where S_i = bond valence of bond i , R_0 = constant dependent on the bonded elements, R_i = bond length of bond i , and $B = 0.370$. V = predicted valence for a site. $V - S_i$ = residual charge on site i . $R_0(\text{W}-\text{O}) = 1.917$, $R_0(\text{W}-\text{F}) = 1.83$. Bond valence sum for the tungsten ($\sum S_i$) = 5.84. ^c Reference 5.

in Teflon (fluoro-ethylene-propylene) "pouches".¹⁰ The pouches were sealed and placed in a 2000 mL autoclave filled with 600 mL of H_2O . The autoclave was heated for 24 h at 150 °C and cooled to room temperature over an additional 24 h. The pouches were removed from the autoclave and opened in air. Products were recovered by filtration. The additional step of washing the products with acetone to remove recrystallized pyrazine solvent was necessary in the case of $\text{Cu}(\text{pyz})_2\text{WO}_2\text{F}_4 \cdot (\text{pyz})(\text{H}_2\text{O})$. Yields are typically 30–70% and were phase pure based on powder X-ray diffraction.

$[\text{pyH}]_2[\text{Cu}(\text{py})_4(\text{WO}_2\text{F}_4)_2]$. Single crystals of $[\text{pyH}]_2[\text{Cu}(\text{py})_4(\text{WO}_2\text{F}_4)_2]$ were synthesized by placing 6.1×10^{-2} g (7.6×10^{-4} mol) of CuO and 3.5×10^{-1} g (1.5×10^{-3} mol) of WO_3 in a Teflon pouch. To the pouch were added 5.9×10^{-1} g (2.2×10^{-3} mol) of $(\text{HF})_4$, pyridine, 1.5 g (1.9×10^{-2} mol) of pyridine, and 6.1×10^{-2} g (3.4×10^{-3} mol) of H_2O . Blue crystals were recovered in approximately 60% yield (based on tungsten).

$\text{Cu}(\text{pyz})_2\text{WO}_2\text{F}_4 \cdot (\text{pyz})(\text{H}_2\text{O})$. Single crystals of $\text{Cu}(\text{pyz})_2\text{WO}_2\text{F}_4 \cdot (\text{pyz})(\text{H}_2\text{O})$, phases I and II, were synthesized by placing 4×10^{-2} g (5×10^{-4} mol) of CuO and 5.8×10^{-2} g (2.5×10^{-4} mol) of WO_3 in a Teflon pouch. To the pouch were added 6.4×10^{-1} g (2.4×10^{-3} mol) of $(\text{HF})_4$, pyridine, 8.0×10^{-1} g (1.0×10^{-2} mol) of pyrazine (pyz), and 3.0×10^{-2} g (1.6×10^{-3} mol) of H_2O . A mixture of pleochroic¹¹ blue/green crystals of $\text{CuW}(\text{pyz})_2\text{O}_2\text{F}_4 \cdot (\text{pyz})(\text{H}_2\text{O})$ polymorph I and light blue crystals of $\text{CuW}(\text{pyz})_2\text{O}_2\text{F}_4 \cdot (\text{pyz})(\text{H}_2\text{O})$ polymorph II were recovered in approximately 60% yield (based on copper).

Crystallographic Determination. Relevant crystallographic data are listed in Table 3. All calculations were performed using the TEXSAN crystallographic software package from Molecular Structure Corporation.¹² The structures were solved by direct methods¹³ and expanded using Fourier techniques.¹⁴ Detailed crystallographic information for all three structures is available in the Supporting Information in CIF format.

(10) Harrison, W. T. A.; Nenoff, T. M.; Gier, T. E.; Stucky, G. D. *Inorg. Chem.* **1993**, *32*, 2437.

(11) Wahlstrom, E. E. *Optical Crystallography*, 5th ed.; John Wiley and Sons: New York, 1979; p 232.

(12) TEXSAN: *Crystal Structure Analysis Package*; Molecular Structure Corp.: The Woodlands, TX, 1985 and 1992.

Table 3. Crystallographic Data for $[\text{pyH}]_2[\text{Cu}(\text{py})_4(\text{WO}_2\text{F}_4)_2]$ and $\text{CuW}(\text{pyz})_2\text{O}_2\text{F}_4 \cdot (\text{pyz})(\text{H}_2\text{O})$ Polymorphs I and II

$[\text{pyH}]_2[\text{Cu}(\text{py})_4(\text{WO}_2\text{F}_4)_2]$	
empirical formula: $\text{C}_{30}\text{H}_{32}\text{CuF}_8\text{N}_6\text{O}_4\text{W}_2$	$T = -120(1)^\circ\text{C}$
fw: 1123.85	$\lambda = 0.71069 \text{ \AA}$
space group: $I4_122$ (No. 98)	$\rho_{\text{calcd}} = 1.904 \text{ g/cm}^3$
$a = 11.339(2) \text{ \AA}$	$\rho_{\text{obsd}} = 1.898(4)^a \text{ g/cm}^3$
$c = 30.489(6) \text{ \AA}$	$\mu = 64.8 \text{ cm}^{-1}$
$V = 3920(1) \text{ \AA}^3$	$R^b = 0.036$
$Z = 4$	$R_w^c = 0.029$

$\text{CuW}(\text{pyz})_2\text{O}_2\text{F}_4 \cdot (\text{pyz})(\text{H}_2\text{O})$	
polymorph I	polymorph II
empirical formula: $\text{C}_{12}\text{H}_{14}\text{CuF}_4\text{N}_6\text{O}_3\text{W}$	empirical formula: $\text{C}_{12}\text{H}_{14}\text{CuF}_4\text{N}_6\text{O}_3\text{W}$
fw: 613.67	fw: 613.67
space group: $I4/mcm$ (No. 140)	space group: $P4/mmm$ (No. 123)
$a = 9.745(1) \text{ \AA}$	$a = 6.886(3) \text{ \AA}$
$c = 16.565(3) \text{ \AA}$	$c = 8.300(2) \text{ \AA}$
$V = 1573.1(3) \text{ \AA}^3$	$V = 393.6(2) \text{ \AA}^3$
$Z = 4$	$Z = 1$
$T = -120(1)^\circ\text{C}$	$T = -120(1)^\circ\text{C}$
$\lambda = 0.71069 \text{ \AA}$	$\lambda = 0.71069 \text{ \AA}$
$\rho_{\text{calcd}} = 2.591 \text{ g/cm}^3$	$\rho_{\text{calcd}} = 2.589 \text{ g/cm}^3$
$\rho_{\text{obsd}} = 2.57(2)^a \text{ g/cm}^3$	$\rho_{\text{obsd}} = 2.55(2)^a \text{ g/cm}^3$
$\mu = 87.43 \text{ cm}^{-1}$	$\mu = 87.36 \text{ cm}^{-1}$
$R^b = 0.040$	$R^b = 0.037$
$R_w^c = 0.045$	$R_w^c = 0.040$

^a Density measured by flotation pycnometry at 24 °C. ^b $R = \sum |F_o| - |F_c| / \sum |F_o|$. ^c $R_w = [\sum w(|F_o| - |F_c|)^2 / \sum w(F_o)^2]^{1/2}$.

Crystal Structure of $[\text{pyH}]_2[\text{Cu}(\text{py})_4(\text{WO}_2\text{F}_4)_2]$. On the basis of systematic absences and successful solution and refinement of the structure, the space group was determined to be $I4_122$ (No. 98). Anisotropic refinement of C(3) was non-positive definite, so it was refined isotropically. All other non-hydrogen atoms were refined anisotropically. Hydrogen atoms were placed in idealized positions. The asymmetric unit contains only three unique atoms for the pyridinium cation, indicating disorder between nitrogen and carbon. N(3) and C(9) were constrained over the same general position, resulting in N(3)–H⁺...F(3) hydrogen bonding. The atomic X-ray scattering factors of oxygen and fluorine are similar, so bond valence relationships were used to determine the positions of each around the tungsten cation. The short bond (1.756(8) Å) between tungsten and one ligand (O(3)) indicated that it was occupied by an oxide ligand, while the long bond trans to the oxygen was assigned to a fluoride ligand. Intermediate bond lengths to the two remaining ligand sites indicated disorder between the second oxide and the three remaining fluorides (O/F(1) and O/F(2)) were each disordered $1/4$ O and $3/4$ F. The space group is non-centrosymmetric, so the atomic coordinates were inverted and the structure re-refined. The reported coordinates are those resulting in the lower $R(F)$ value. $[\text{pyH}]_2[\text{Cu}(\text{py})_4(\text{WO}_2\text{F}_4)_2]$ is isostructural with the previously reported $[\text{pyH}]_2[\text{Cu}(\text{py})_4(\text{NbOF}_5)_2]$.¹⁵

Crystal Structure of $\text{Cu}(\text{pyz})_2\text{WO}_2\text{F}_4 \cdot (\text{pyz})(\text{H}_2\text{O})$ Polymorph I. On the basis of systematic absences and successful solution and refinement of the structure, the space group was determined to be $I4/mcm$ (No. 40). All atoms were refined anisotropically. Hydrogen atoms on pyrazine were not located. Oxygen and fluorine were disordered $1/2$ each over the bridging O/F(1) site, and disordered $1/4$ and $3/4$ respectively over the nonbridging position O/F(2) in accordance with the stoichiometry and known *cis* configuration of the $[\text{WO}_2\text{F}_4]^{2-}$ anion. Unbound solvent pyrazine and water molecules apparently rotate freely in the

- (13) (a) Sheldrick, G. M. *SHELXS86*. In *Crystallographic Computing 3*; Sheldrick, G. M., Kruger, C., Goddard, R., Eds.; Oxford University Press: Oxford, U.K., 1985; p 175. (b) Altomare, A.; Casciaro, M.; Giacovazzo, C.; Guagliardi, A. *J. Appl. Crystallogr.* **1993**, *26*, 343.
- (14) Beurskens, P. T.; Admiraal, G.; Beurskens, G.; Bosman, W. P.; de Gelder, R.; Israel, R.; Smits, J. M. M. DIRDIF-94. The DIRDIF-94 program system. Technical Report of the Crystallography Laboratory, University of Nijmegen: Nijmegen, The Netherlands, 1994.
- (15) Halasyamani, P.; Willis, M. J.; Stern, C. L.; Lundquist, P. M.; Wong, G. K.; Poeppelmeier, K. R. *Inorg. Chem.* **1996**, *35*, 1367.

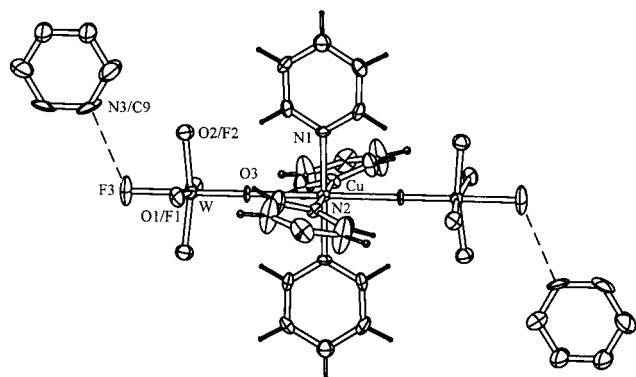

Figure 2. Thermal ellipsoid plot (50% probability) of the $[\text{Cu}(\text{py})_4(\text{WO}_2\text{F}_4)_2]^{2-}$ anion hydrogen bonded to the pyridinium cations in $[\text{pyH}]_2[\text{Cu}(\text{py})_4(\text{WO}_2\text{F}_4)_2]$.

channels of the structure as modeled by abnormally large thermal ellipsoids for their atoms.

Crystal Structure of $\text{Cu}(\text{pyz})_2\text{WO}_2\text{F}_4 \cdot (\text{pyz})(\text{H}_2\text{O})$ Polymorph II.

On the basis of systematic absences and successful solution and refinement of the structure, the space group was determined to be $P4/mmm$ (No. 123). All atoms were refined anisotropically. Hydrogen atoms on pyrazine were not located. Complex disorder was observed with the $[\text{WO}_2\text{F}_4]^{2-}$ anion, pyrazine ligands on copper, and the free solvent pyrazine molecule each statistically disordered over two possible orientations. The populations of carbon C(1) on the pyrazine ligand and carbon C(2) on the solvent pyrazine are 0.5 to reflect the two possible orientations. The $[\text{WO}_2\text{F}_4]^{2-}$ anion was further disordered as described above (polymorph I) to reflect its stoichiometry and cis configuration. Thus oxide and fluoride ligands were disordered $1/2$ each over the bridging O/F(1) site, while the total population of the nonbridging O/F(2) site was 0.5 to reflect the two possible orientations and disordered $1/4$ O and $3/4$ F. As was observed with polymorph I, the unbound solvent pyrazine and water molecules show abnormally large thermal ellipsoids.

Spectroscopic Measurements. Mid-IR (400–4000 cm^{-1}) spectra were collected using a Biorad FTS-60 FTIR spectrometer operating at a resolution of 2 cm^{-1} .

Results

Dioxo complexes of d^0 metals are expected to adopt a cis configuration in order that the strongly π donating oxide ligands can make maximum use of the available empty d orbitals on the metal.¹⁶ Although crystallographic disorder obscures the true geometry of the $[\text{WO}_2\text{F}_4]^{2-}$ anion in these compounds, infrared spectroscopy can be used to confirm the cis configuration. The symmetric and asymmetric (WO_2) stretching frequencies of the *cis*- $[\text{WO}_2\text{F}_4]^{2-}$ anion are observed in both the infrared and Raman spectra, while a *trans*- $[\text{WO}_2\text{F}_4]^{2-}$ geometry would show only the asymmetric stretch in the infrared and the symmetric stretch in the Raman. The infrared spectra of all reported compounds containing the $[\text{WO}_2\text{F}_4]^{2-}$ anion show the characteristic stretching frequencies of the *cis*- $[\text{WO}_2\text{F}_4]^{2-}$ anion ($\nu_s(\text{WO}_2) = 950\text{--}960 \text{ cm}^{-1}$, $\nu_{as}(\text{WO}_2) = 900\text{--}910 \text{ cm}^{-1}$).^{16,17}

$[\text{pyH}]_2[\text{Cu}(\text{py})_4(\text{WO}_2\text{F}_4)_2]$. The structure of $[\text{pyH}]_2[\text{Cu}(\text{py})_4(\text{WO}_2\text{F}_4)_2]$ is built from $[\text{Cu}(\text{py})_4(\text{WO}_2\text{F}_4)_2]^{2-}$ anions hydrogen bonded to pyridinium (pyH^+) cations. These anions comprise two smaller $[\text{WO}_2\text{F}_4]^{2-}$ anions coordinated to a central $[\text{Cu}(\text{py})_4]^{2+}$ cation (Figure 2). The divalent copper atoms are Jahn–Teller active, so it is not surprising to find that the coordination environment around the copper cations consists of four equatorial pyridine ligands and two longer axial bonds to oxide ligands

Table 4. Crystallographic Bond Lengths for $[\text{WO}_2\text{F}_4]^{2-}$ Anions

bond	O/F occupancy	bond length (Å)	ave (Å)
$\text{Cs}_2\text{WO}_2\text{F}_4$			
$\text{W}-\text{X} \times 6$	$1/3\text{O}:2/3\text{F}$	1.891(5)	
$\text{Cu}(\text{pyz})_2\text{WO}_2\text{F}_4 \cdot (\text{pyz})(\text{H}_2\text{O})$ Polymorph I			
$\text{W}-\text{X}(1) \times 2$	$1/2\text{O}:1/2\text{F}$	1.894(6)	1.87
$\text{W}-\text{X}(2) \times 4$	$1/4\text{O}:3/4\text{F}$	1.855(4)	
$\text{Cu}(\text{pyz})_2\text{WO}_2\text{F}_4 \cdot (\text{pyz})(\text{H}_2\text{O})$ Polymorph II			
$\text{W}-\text{X}(1) \times 2$	$1/2\text{O}:1/2\text{F}$	1.906(7)	1.88
$\text{W}-\text{X}(2) \times 4$	$1/4\text{O}:3/4\text{F}$	1.869(9)	
$\text{Cu}(\text{py})_4\text{WO}_2\text{F}_4$			
$\text{W}-\text{X}(1) \times 2$	$1/2\text{O}:1/2\text{F}$	1.891(4)	1.86
$\text{W}-\text{X}(2) \times 2$	$1/2\text{O}:1/2\text{F}$	1.855(4)	
$\text{W}-\text{F}(3)$		1.883(4)	
$\text{Cu}(\text{H}_2\text{O})_2(\text{py})_2\text{WO}_2\text{F}_4$			
$\text{W}-\text{X}(1)$	$1/2\text{O}:1/2\text{F}$	1.855(6)	1.88
$\text{W}-\text{X}(2)$	$1/2\text{O}:1/2\text{F}$	1.876(6)	
$\text{W}-\text{F}(3)$		1.872(6)	
$\text{W}-\text{F}(4)$		1.870(6)	
$\text{W}-\text{X}(5)$	$1/2\text{O}:1/2\text{F}$	1.872(6)	
$\text{W}-\text{X}(6)$	$1/2\text{O}:1/2\text{F}$	1.926(6)	
$[\text{pyH}]_2[\text{Cu}(\text{py})_4(\text{WO}_2\text{F}_4)_2]$			
$\text{W}-\text{X}(1) \times 2$	$1/4\text{O}:3/4\text{F}$	1.901(7)	1.89
$\text{W}-\text{X}(2) \times 2$	$1/4\text{O}:3/4\text{F}$	1.886(5)	
$\text{W}=\text{O}(3)$		1.756(8)	
$\text{W}-\text{F}(3)$		2.022(8)	
$\text{Na}_2\text{WO}_2\text{F}_4$			
$\text{W}=\text{O} \times 2$		1.750(9)	1.91
$\text{W}-\text{F}(1) \times 2$		1.932(8)	
$\text{W}-\text{F}(2) \times 2$		2.039(9)	

of the $[\text{WO}_2\text{F}_4]^{2-}$ anion. W(VI) is distorted from the center of its octahedron toward the oxide ligand bridging to copper. The result is a short $\text{W}=\text{O}$ bond and a long $\text{W}-\text{F}(3)$ bond in the trans position (Table 4). On the basis of the known cis configuration of the $[\text{WO}_2\text{F}_4]^{2-}$ anion, the four ligands in the cis positions must be disordered between the remaining oxide and three fluorides. A similar disorder effect is seen in $\text{K}_2\text{MoO}_2\text{F}_4$.^{8,18} The structure contains planes (001) of parallel, end to end clusters, with each layer rotated 90° with respect to the one beneath it. This creates a 4_1 screw axis in the structure. The infrared spectrum of the compound confirms the presence of coordinated pyridine (1608 and 643 cm^{-1}) and pyridinium (1630, 1534, 1335, and 1255 cm^{-1})¹⁹ and the cis nature of the $[\text{WO}_2\text{F}_4]^{2-}$ anion ($\nu_s(\text{WO}_2) = 960 \text{ cm}^{-1}$, $\nu_{as}(\text{WO}_2) = 905 \text{ cm}^{-1}$).

$\text{Cu}(\text{pyz})_2\text{WO}_2\text{F}_4 \cdot (\text{pyz})(\text{H}_2\text{O})$ Polymorph I. The copper cations in $\text{Cu}(\text{pyz})_2\text{WO}_2\text{F}_4 \cdot (\text{pyz})(\text{H}_2\text{O})$ are bridged by four pyrazine ligands to form $[\text{Cu}(\text{pyz})_{4/2}]^{2n+}$ infinite square nets in the (001) plane. The axial copper positions are coordinated by $[\text{WO}_2\text{F}_4]^{2-}$ anions, which link the infinite nets together in the *c* direction. The resulting three-dimensional structure (Figure 3a) contains channels running along the *c* direction which are filled with H_2O and pyrazine solvent molecules. The connectivity is similar to that previously found in $\text{Cu}(\text{pyz})_2\text{NbOF}_5 \cdot (\text{pyz})(\text{H}_2\text{O})$.²⁰ W(VI) is located at the center of a nearly regular octahedron of O/F ligands (Table 4). The possibility of fluoride ligands occupying both bridging sites was rejected as the coppers would have to coordinate to the two least nucleophilic $[\text{WO}_2\text{F}_4]^{2-}$ ligands. The two bridging sites were therefore disordered $1/2$ O

(18) Pinsker, G. Z.; Kuznetsov, V. G. *Kristallografiya* **1968**, *13*, 74. (The structure is reported with *trans*- $[\text{MoO}_2\text{F}_4]^{2-}$, despite infrared evidence indicating cis coordination. A disordered cis model is more likely correct.)

(19) Gill, N. S.; Nuttall, R. H.; Scaife, D. E.; Sharp, D. W. A. *J. Inorg. Nucl. Chem.* **1961**, *18*, 79.

(20) Halasyamani, P.; Heier, K. R.; Willis, M. J.; Stern, C. L.; Poeppelmeier, K. R. *Z. Anorg. Allg. Chem.* **1996**, *622*, 479.

(16) Griffith, W. P.; Wickens, T. D. *J. Chem. Soc. A* **1968**, 400.

(17) Pausewang, G.; Schmitt, R.; Dehnicke, K. *Z. Anorg. Allg. Chem.* **1974**, *408*, 1.

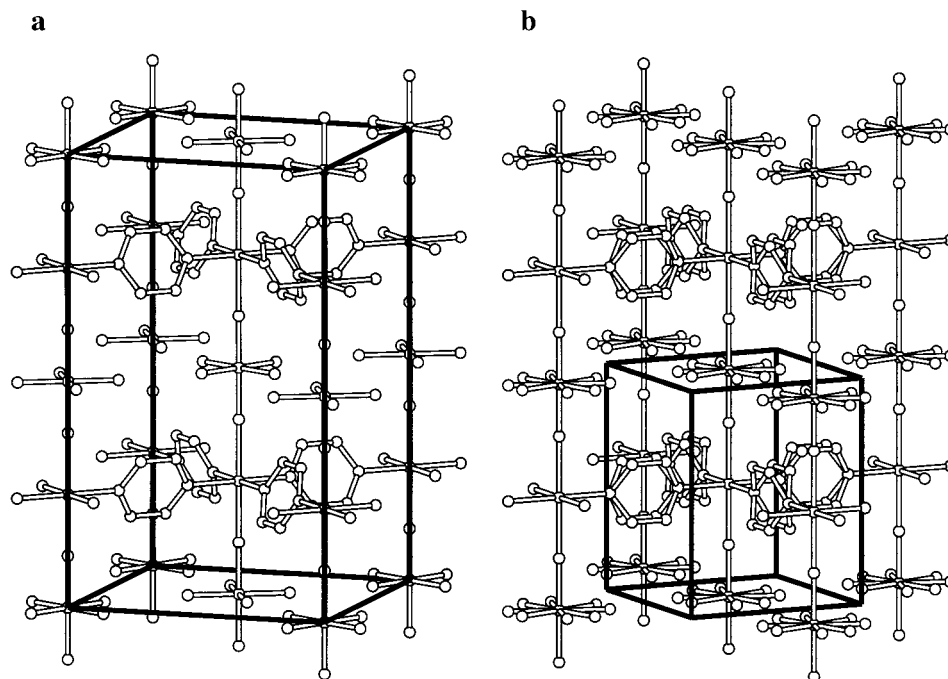

Figure 3. Crystal packing of $\text{Cu}(\text{pyz})_2\text{WO}_2\text{F}_4 \cdot (\text{pyz})(\text{H}_2\text{O})$ (a) polymorph I and (b) polymorph II. Solvent H_2O and pyrazine molecules have been removed for clarity. Pyrazine ligands and $[\text{WO}_2\text{F}_4]^{2-}$ octahedra in polymorph II are disordered over two orientations (50% each, both pictured).

and $1/2$ F, while the four nonbridging ligands were disordered $1/4$ O and $3/4$ F, in agreement with the stoichiometry and cis geometry of the $[\text{WO}_2\text{F}_4]^{2-}$ anion. The infrared spectrum confirms the cis nature of the $[\text{WO}_2\text{F}_4]^{2-}$ anion ($\nu_s(\text{WO}_2) = 960 \text{ cm}^{-1}$, $\nu_{as}(\text{WO}_2) = 907 \text{ cm}^{-1}$).

$\text{Cu}(\text{pyz})_2\text{WO}_2\text{F}_4 \cdot (\text{pyz})(\text{H}_2\text{O})$ Polymorph II. The connectivity of $\text{Cu}(\text{pyz})_2\text{WO}_2\text{F}_4 \cdot (\text{pyz})(\text{H}_2\text{O})$ polymorph II appears to be identical to that of $\text{Cu}(\text{pyz})_2\text{WO}_2\text{F}_4 \cdot (\text{pyz})(\text{H}_2\text{O})$ polymorph I (Figure 3). The crystallographic unit cell of polymorph II (a' , b' , c') is related to the unit cell of polymorph I (a , b , c) by the transformation $a' = (1/\sqrt{2})a$, $b' = (1/\sqrt{2})b$, and $c' = 1/2c$. Polymorph II would appear to be the identical structure modeled in a smaller unit cell of higher symmetry if not for the difference in the macroscopic property of color. Polymorph I shows a distinctive pleochroic effect: appearing green when viewed along the $[001]$ direction and blue when viewed along the $[100]$ and $[010]$ directions. Polymorph II shows no such effect, appearing blue when viewed along all directions. This interesting observation deserves more study.

Discussion

The $[\text{WO}_2\text{F}_4]^{2-}$ anion is usually found disordered in its crystals. The true geometry of $[\text{WO}_2\text{F}_4]^{2-}$ is shown in Figure 1, with the tungsten cation distorted from the center of the octahedron toward the two cis oxides. Despite this distortion, the oxide and fluoride ligands remain in a nearly regular octahedral arrangement. The oxygen–oxygen nonbonded distance is longest at 2.719 Å. The other 11 nonbonded distances average 2.675 Å, with the shortest distance, 2.573 Å, between the fluoride ligands trans to the oxide ligands. A consequence is that the anion is able to orient itself in 12 possible directions while occupying the same space. The 12 possible orientations, one for each edge of the octahedron, are shown in Figure 4. Note that the O and F ligands stay in nearly the same positions as the octahedron is rotated, while the W position shifts around the center. Several, or even all, of these orientations can exist simultaneously within the same crystal and be averaged by the diffraction data into one seemingly undistorted octahedron.

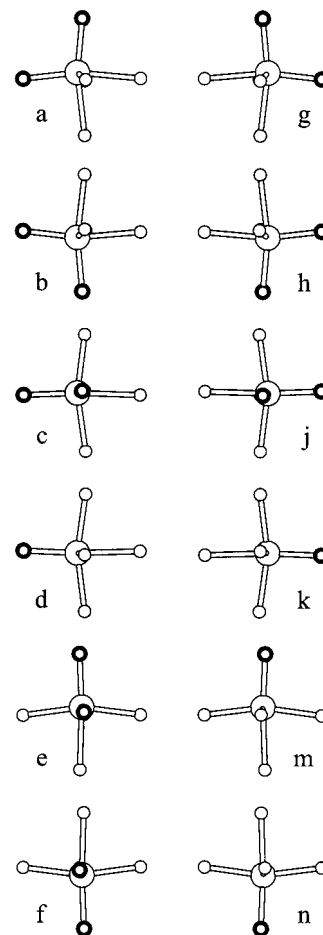

Figure 4. The 12 possible orientations of the $[\text{WO}_2\text{F}_4]^{2-}$ anion in a crystal. Dark and light circles represent oxide and fluoride ligands, respectively. For the compounds reported in this study, cations would be coordinated to the right and left O/F ligands in each case.

Refining relative O/F populations on the disordered $[\text{WO}_2\text{F}_4]^{2-}$ ligands is fruitless because of the similarity of the atomic X-ray

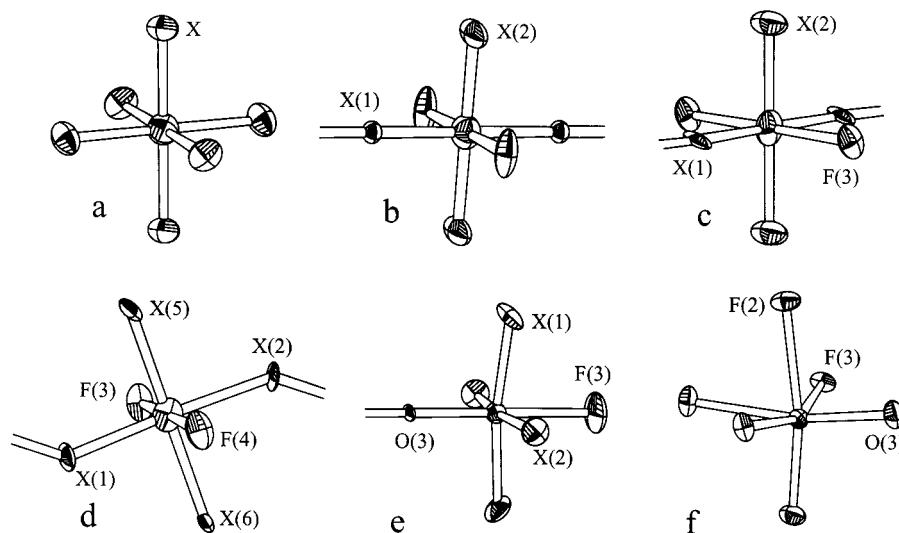

Figure 5. Thermal ellipsoid plots (50% probability) of disordered $[\text{WO}_2\text{F}_4]^{2-}$ anions in (a) $\text{Cs}_2\text{WO}_2\text{F}_4$,⁷ (b) $\text{Cu}(\text{py})_2\text{WO}_2\text{F}_4 \cdot (\text{pyz})(\text{H}_2\text{O})$ polymorph I, (c) $\text{Cu}(\text{py})_4\text{WO}_2\text{F}_4$,⁹ (d) $\text{Cu}(\text{H}_2\text{O})_2(\text{py})_2\text{WO}_2\text{F}_4$,⁹ and (e) $[\text{pyH}]_2[\text{Cu}(\text{py})_4(\text{WO}_2\text{F}_4)_2]$ and (f) the ordered $[\text{WO}_2\text{F}_4]^{2-}$ anion in $\text{Na}_2\text{WO}_2\text{F}_4$.⁵ Atoms marked with an X are disordered between O^{2-} and F^- (see Table 4.) Additional views of $\text{Cu}(\text{py})_4\text{WO}_2\text{F}_4$ and $\text{Cu}(\text{H}_2\text{O})_2(\text{py})_2\text{WO}_2\text{F}_4$ are available in the Supporting Information.

scattering factors and neutron cross sections of O^{2-} and F^- . However, insight into the disorder mechanisms can be extracted from bond lengths (short bonds belong to oxides: Table 4) and through close examination of anisotropic thermal ellipsoids (Figure 4). The tungsten thermal ellipsoid in a disordered $[\text{WO}_2\text{F}_4]^{2-}$ anion reflects more than the simple thermal motion of the atom. In the absence of systematic errors it may also represent an average of the various distortions from the center of the octahedron. For example, the thermal ellipsoid of a tungsten cation that is averaged over all 12 of its possible distortions would appear as an unusually large sphere, while one that is only averaged over four coplanar distortions would appear as a thin round disk.

The physical size and shape of the anion does not normally limit which orientations are possible; rather the anion's negative charge, which is not distributed evenly among the two oxide and four fluoride ligands (Table 2), can cause certain orientations to be favored over others. Cations in a crystal structure will coordinate to the most nucleophilic ligands on $[\text{WO}_2\text{F}_4]^{2-}$, which are the two oxide ligands and the fluorides trans to them. The simplest example is illustrated by the structure of $\text{Cu}(\text{py})_2\text{WO}_2\text{F}_4 \cdot (\text{pyz})(\text{H}_2\text{O})$ (polymorph I) in which eight orientations are equally favorable (Figure 4: a–d, g–k). The $[\text{WO}_2\text{F}_4]^{2-}$ anion is coordinated on trans corners by two $[\text{Cu}(\text{py})_2]^{2+}$ cations (the right and left O/F ligands in Figure 4). The only constraint on the orientation of the anion is that one oxide ligand and its trans fluoride ligand (the most nucleophilic ligands) must always coordinate to the two coppers, thus eliminating the four orientations where two fluoride ligands would coordinate (Figure 4: e, f, m, n). The result is a large spherical tungsten thermal ellipsoid (Figure 5b) and tungsten–ligand bond distances slightly shorter than the average of the tungsten–ligand bond distances in the ordered anion (Table 4). The disordered tungsten–ligand bond distances are expected to be shorter²¹ because, in the ordered anion, tungsten is displaced from the center of the octahedron, making the sum of the bond lengths $\text{O}=\text{W} + \text{W}-\text{F}(\text{trans})$ greater than the distance between O and F(trans). In a disordered anion, tungsten occupies the center of the octahedron and $\text{O}=\text{W} + \text{W}-\text{F}(\text{trans})$ is exactly equal to

the distance between O and F(trans). Since the distance between O and F(trans) remains constant ($\sim 3.78(1)$ Å), the bond lengths in the disordered anion must be shorter. Approximately the same result is observed if all 12 possible orientations are present as is the case in $\text{Cs}_2\text{WO}_2\text{F}_4$ (see Figure 5a and Table 4).

In the case of $\text{Cu}(\text{py})_4\text{WO}_2\text{F}_4$,⁹ the disorder mechanism appears to be more constrained. This structure consists of infinite linear chains of alternating $[\text{Cu}(\text{py})_4]^{2+}$ cations and $[\text{WO}_2\text{F}_4]^{2-}$ anions, shifting directions from $[110]$ to $[-110]$ every $c/2$. One oxide ligand on the anion and the fluoride ligand trans to it must occupy positions bridging to the $[\text{Cu}(\text{py})_4]^{2+}$ cations, similar to $\text{Cu}(\text{py})_2\text{WO}_2\text{F}_4 \cdot (\text{pyz})(\text{H}_2\text{O})$. However, the thin disk-shaped thermal ellipsoid of the tungsten (Figure 5c) indicates that only four coplanar orientations are present (Figure 4: a, b, g, h). The more anisotropic environment around the $[\text{WO}_2\text{F}_4]^{2-}$ anion as compared to $\text{Cu}(\text{py})_2\text{WO}_2\text{F}_4 \cdot (\text{pyz})(\text{H}_2\text{O})$ appears to favor placing the nucleophilic oxide and its trans fluoride in only two of the four nonbridging positions.

By increasing the anisotropy of the crystal environment around $[\text{WO}_2\text{F}_4]^{2-}$ further, still more orientations are eliminated. In $\text{Cu}(\text{py})_2(\text{H}_2\text{O})_2\text{WO}_2\text{F}_4$,⁹ the crystalline environment around $[\text{WO}_2\text{F}_4]^{2-}$ is altered by using the $[\text{Cu}(\text{py})_2(\text{H}_2\text{O})_2]^{2+}$ cation which has two trans pyridine ligands and two trans water ligands. Again the nucleophilic oxide ligand and its trans fluoride ligand bridge to the copper cations forming infinite chains of alternating cations and anions (Figure 6). However, in this case the cation–anion chains bend to allow hydrogen bonding between the H_2O ligands on the cation and O/F ligands on the anion. This has two effects on the allowed orientations of the $[\text{WO}_2\text{F}_4]^{2-}$ anion. First, only the nucleophilic oxide ligands and their trans fluorides may occupy the hydrogen bond accepting sites, reducing the number of possible orientations to four (Figure 4: a, b, g, h, copper cations coordinated to left and right O/F ligands, hydrogen bond accepting sites at the top and bottom). Second, because of the close contact between the tungsten and copper cations resulting from the bent chains, copper–tungsten repulsive forces become important. Two of the possible orientations (e.g., Figure 4: a, h) must move the copper and tungsten cations closer together while the other two possible orientations (e.g., Figure 4: b, g) maximize the copper–tungsten distance. The resulting tungsten thermal ellipsoid

(21) Brown, I. D.; Shannon, R. D. *Acta Crystallogr., Sect. A* **1973**, *29*, 266.

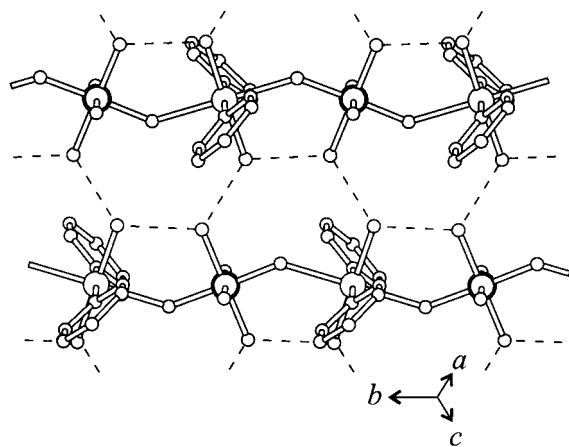

Figure 6. Adjacent cation-anion zigzag chains in $\text{Cu}(\text{H}_2\text{O})_2(\text{pyz})_2\text{WO}_2\text{F}_4$. Dashed lines indicate hydrogen bond interactions. Tungsten cations are represented by the large dark circles.

(Figure 5d) is a flat oval reflecting its two possible positions. Despite the reduction of possible orientations to only two, the resulting bond lengths and angles are still disordered (Table 4), as oxide and fluoride ligands still occupy the same crystallographic positions.

Another way to increase the anisotropy of the crystalline environment around the $[\text{WO}_2\text{F}_4]^{2-}$ anion is to simultaneously crystallize it with two different cations. This technique has been successful in producing ordered structures with the $[\text{NbOF}_5]^{2-}$ and $[\text{MoO}_2\text{F}_4]^{2-}$ anions.² In $[\text{pyH}]_2[\text{Cu}(\text{py})_4(\text{WO}_2\text{F}_4)_2]$ one of the oxide ligands on $[\text{WO}_2\text{F}_4]^{2-}$ binds to the $[\text{Cu}(\text{py})_4]^{2+}$ cation, while the pyridinium (pyH^+) cation hydrogen bonds to the trans fluoride. The two different cations ensure that the bridging oxide and its trans fluoride cannot be interchanged. As a result, only the four orientations with an oxide ligand pointing in the same direction are possible for the anion (Figure 4: a–d). The result is one short $\text{W}=\text{O}$ bond and one long $\text{W}-\text{F}$ bond (Table 4). However, the anion is still free to rotate around the $\text{O}=\text{W}-\text{F}$ axis, leaving the second oxide ligand and its trans fluoride counterpart disordered along with the other two remaining fluorides.

Comparison of the negative charge distribution, as calculated by the bond valence sum method,²² on the $[\text{NbOF}_5]^{2-}$, $[\text{MoO}_2\text{F}_4]^{2-}$, and $[\text{WO}_2\text{F}_4]^{2-}$ anions reveals why this ordering technique is not totally successful for the $[\text{WO}_2\text{F}_4]^{2-}$ case. Figure 7 shows each anion with the most nucleophilic ligands circled. In the case of $[\text{NbOF}_5]^{2-}$ the nucleophilic ligands are in trans positions. When the two different cations coordinate to these sites, the anion is only free to rotate around the $\text{O}=\text{Nb}-\text{F}$ axis. Since this rotation is consistent with the symmetry of the anion (C_{4v}), an ordered $[\text{NbOF}_5]^{2-}$ is observed. The nucleophilic ligands on the $[\text{MoO}_2\text{F}_4]^{2-}$ anion are located in cis positions. Coordination of cations to these two sites removes all rotational freedom from the anion, locking it into a single orientation. However, in contrast to the $[\text{NbOF}_5]^{2-}$ and $[\text{MoO}_2\text{F}_4]^{2-}$ anions, the $[\text{WO}_2\text{F}_4]^{2-}$ anion has four nucleophilic ligands in a coplanar arrangement. The metal-oxo bonds are longer in the $[\text{WO}_2\text{F}_4]^{2-}$ anion with respect to the $[\text{MoO}_2\text{F}_4]^{2-}$ anion. The shorter Mo-oxo bonds leave very little negative charge on the oxide ligands while the longer W-oxo bonds leave negative charge which is approximately equivalent in magnitude to that on the fluoride ligands trans to the oxide ligands.²² Either cis or trans coordination of two cations on the $[\text{WO}_2\text{F}_4]^{2-}$ anion is possible, but cation-cation repulsion strongly favors trans coordination. The

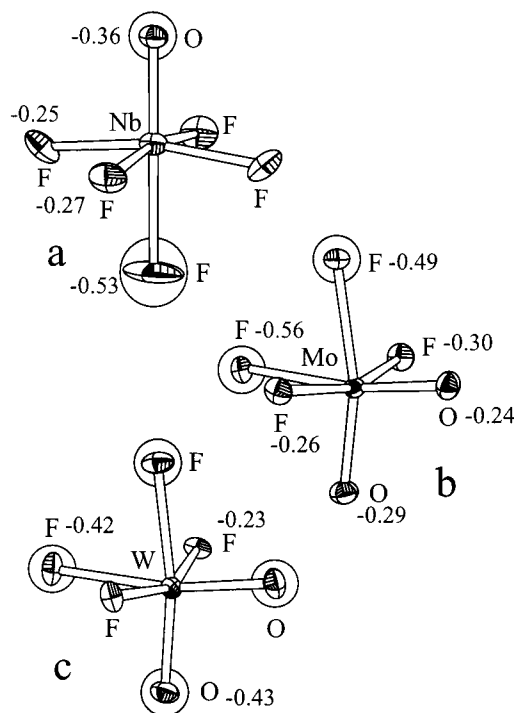

Figure 7. Thermal ellipsoid plots (50%) probability for the (a) $[\text{NbOF}_5]^{2-}$, (b) $[\text{MoO}_2\text{F}_4]^{2-}$, and (c) $[\text{WO}_2\text{F}_4]^{2-}$ anions. The most nucleophilic ligands of each anion are circled. The magnitude of the negative charge on each ligand is also given.

trans coordination provides a situation identical to the $[\text{NbOF}_5]^{2-}$ case, except that rotation around the $\text{O}=\text{W}-\text{F}$ axis is inconsistent with the symmetry of $[\text{WO}_2\text{F}_4]^{2-}$ (C_{2v}) and the anion remains only partially ordered.

Conclusion

Partial ordering of the $[\text{WO}_2\text{F}_4]^{2-}$ anion has been achieved by providing it with anisotropic crystalline environments. One way to achieve complete order in the $[\text{WO}_2\text{F}_4]^{2-}$ anion would be to combine the ordering effects seen in $\text{Cu}(\text{py})_2(\text{H}_2\text{O})_2\text{WO}_2\text{F}_4$ and $[\text{pyH}]_2[\text{Cu}(\text{py})_4(\text{WO}_2\text{F}_4)_2]$. Hydrogen bonding and cation-cation repulsion in $\text{Cu}(\text{py})_2(\text{H}_2\text{O})_2\text{WO}_2\text{F}_4$ restrict the anion to only two orientations: one with the bridging oxide ligand in one direction, the other with the bridging oxide in the opposite direction (Figure 4: b, g). The two different cations in $[\text{pyH}]_2[\text{Cu}(\text{py})_4(\text{WO}_2\text{F}_4)_2]$ ensure that only one direction is available for the bridging oxide, which would limit the anion to a single orientation. Efforts are underway to find the appropriate system to produce such a structure.

Acknowledgment. The authors gratefully acknowledge support from the National Science Foundation, Solid State Chemistry (Awards No. DMR-9412971 and DMR-9727516), support from the MRSEC program of the National Science Foundation (DMR-9632472) at the Materials Research Center of Northwestern University. This work made use of Central Facilities supported by the MRSEC program of the National Science Foundation (Grant DMR-9632472) at the Materials Research Center of Northwestern University.

Supporting Information Available: Stereoscopic view of the crystal packing of $[\text{pyH}]_2[\text{Cu}(\text{py})_4(\text{WO}_2\text{F}_4)_2]$, thermal ellipsoid plots of $[\text{pyH}]_2[\text{Cu}(\text{py})_4(\text{WO}_2\text{F}_4)_2]$ and $\text{Cu}(\text{pyz})_2\text{WO}_2\text{F}_4 \cdot (\text{pyz})(\text{H}_2\text{O})$ polymorphs I and II, and alternate views of the $[\text{WO}_2\text{F}_4]^{2-}$ anions in $\text{Cu}(\text{py})_4\text{WO}_2\text{F}_4$ and $\text{Cu}(\text{py})_2(\text{H}_2\text{O})_2\text{WO}_2\text{F}_4$. Three X-ray crystallographic files, in CIF format, are available. This material is available free of charge via the Internet at <http://pubs.acs.org>.

(22) Norquist, A. J.; Heier, K. R.; Stern, C. L.; Poeppelmeier, K. R. *Inorg. Chem.* **1998**, *37*, 6495.